

Si-5351C Synthesizer board Drilling/Cutting template

Version 1, May 2019

Applicable to an 80 x 50 x 20 mm extruded aluminium enclosure

Front Faceplate

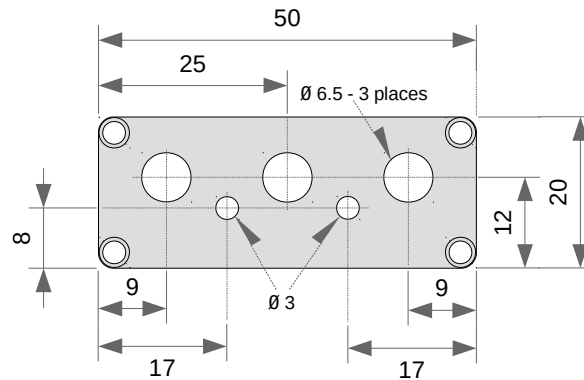

Rear Faceplate

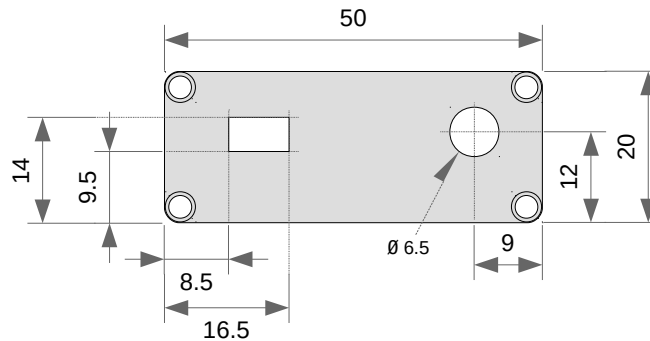

Notes:

- 1) All dimensions shown in millimeters.
- 2) Views are from exterior sides of faceplates, looking at the instrument when fully assembled.
- 3) Drawings are at 1:1 scale with actual faceplates.
- 4) The user may cut these faceplate outlines and use as templates for easier marking and punching.